

SAFE T DOLLY WITH HANDLE

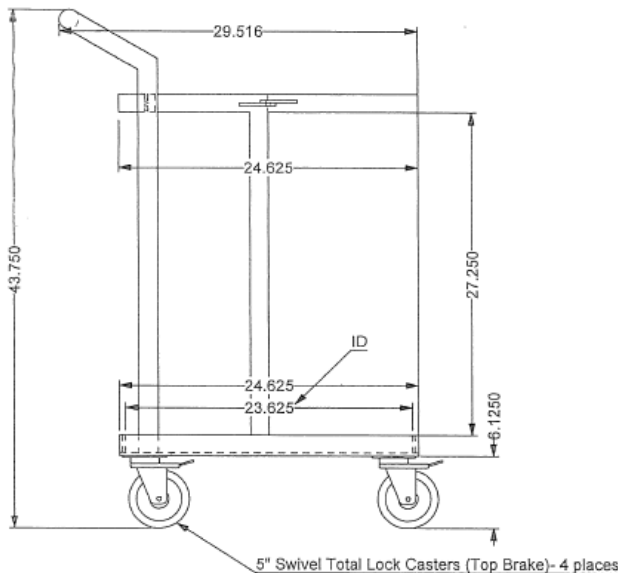

MODEL 008216

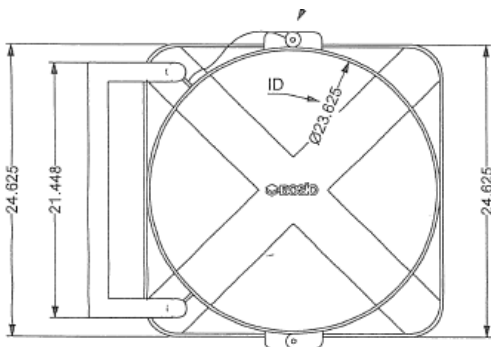

Key Features:

- Easy open gate for front access
- Spring loaded pin for secure closure
- Non-marking, chemical-resistant stainless steel casters

Specifications:

- Model Number: 008216
- Capacity: 200 liters or 55-gallon drums
- Construction Material: Type 304 SS #4 Finish
- Caster Material: Stainless steel
- Caster Type: Swivel casters with locking mechanism

- Weight: 35 lbs (approx.)

Benefits:

- Enhanced safety and secure drum transportation
- Easy maneuverability with stainless steel casters
- Versatile and durable for various environments

Applications:

- Manufacturing facilities
- Warehouses
- Laboratories
- Clean rooms



Manufactured By: Bosio Metal Specialties Inc. USA

WWW.BOSIOSTAINLESS.NET

1-215-699-4100

